

The image features a large, light blue watermark of the Wefco logo in the background. The logo consists of a stylized 'W' followed by the letters 'wefco' in a lowercase, sans-serif font. Below the 'wefco' text is a horizontal line, and underneath that line, the word 'marketing' is written in a smaller, lowercase, sans-serif font. The watermark is semi-transparent and centered on the page.

MALARIA VECTOR CONTROL

marketing

IRS TRAINING MANUAL

**The application of insecticides, correct use and care
of equipment used, and staff training.**

Prepared by: W. E. Farrell, Wefco Marketing International,
Pietermaritzburg, RSA.

The logo for Wefco Marketing features a large, stylized 'W' on the left side, composed of several overlapping, rounded, light blue shapes. To the right of the 'W', the word 'wefco' is written in a light blue, lowercase, sans-serif font. Below 'wefco', a thin horizontal line spans the width of the text. Underneath this line, the word 'marketing' is written in a light grey, lowercase, sans-serif font, with wide letter spacing.

m a r k e t i n g

TABLE OF CONTENTS

Introduction

CHAPTER: 1

The Control of Malaria Vectors

Introduction

Chemical control

Keys to successful chemical control

Larviciding

Residual spraying

CHAPTER: 2

Application of Insecticides

Equipment for insecticide application

The Hudson X-Pert compression sprayer

Nozzles

Testing nozzles

Practical operation of the Hudson X-pert sprayer

Examples of the application of IRS insecticides

Application of DDT 75 WP

Application of K-Othrine 250 WP

Application of Icon 10 CS

Application of Impact CS

Application of Ficam WP

CHAPTER: 3

The Training of Spray Men/Women

- Introduction
- Equipment and materials required for training
- Preparation of the training area
- Step-by-step spraying training

INTRODUCTION

Much of the success in controlling Malaria in southern Africa can be attributed to the scientific approach employed, in the correct use of appropriate insecticides and spraying techniques by well-informed and motivated members of Malaria Control teams.

At a time when resources for Malaria control are becoming more available by international funding organisations, strains of resistant parasites are becoming more widespread and an effective vaccine still eludes us, it is essential that the proven tools we have at our disposal should be best used for the well-being of our populations.

This manual was written to enable Environmental Health Officers and Programme Managers involved in Malaria control in southern Africa to assess the training needs of their subordinates and to equip them with the knowledge and skills necessary to train members of the control teams on aspects of supervision, assessment and evaluation of programme efficiency.

The skilful application of insecticides is even more important at the present time than it has been in the past with the advent of new effective insecticides to replace DDT. These are of varying toxicity and require safer handling and application techniques and more sophisticated protection measures. Further, correct dosage rates are critical. Correct application with standardised procedures and equipment will only be assured if staff are well informed, trained and motivated.

The Environmental Health Officer/Programme Manager must ensure that all staff involved in the application of insecticides, i.e. Field Officers, Foremen, Trainer of Trainers, Supervisors and Spray-men are trained in line with the Guidelines set out in Chapter 3.

" A malariologist, it has often been said, is a man of all trades. He must be properly trained and spiritually motivated to become one."

"It must be realized that malaria control demands much competence, initiative, responsibility and hard, precise work."

Extracts from:

Malaria

Principles and practice of malariology: Wernsdorfer and McGregor.

CHAPTER: 1

THE CONTROL OF VECTOR MOSQUITOES

INTRODUCTION

Chemical Control of Vector Mosquitoes

The objective of all control measures is to reduce contact between people and infected mosquitoes thereby reducing malaria transmission to the point of **interruption** while minimizing harm to the environment and human health.

Integrated vector management (IVM) refers to the use of a combination of appropriate technologies, and management techniques to bring about effective vector suppression.

Methods currently available are:

- chemical control
- environmental management and source reduction
- personal protection methods
- biological control
- health education.

Chemical Control

Chemical control is one of the important methods of vector control in southern Africa.

It may be aimed at the larval or adult stage of the mosquito life cycle. As chemicals have a short-lived effect on mosquito populations, applications need to be repeated. Since the habitat of the 2 stages differ, the approaches to control and the insecticides and formulations used, also differ.

An. arabiensis, the principal malaria vector in southern Africa, is an opportunistic breeder preferring small temporary pools of water therefore larviciding is not always practical or economically feasible except in specific situations.

The use of residual insecticides directed towards adult mosquitoes remains the preferred method of vector control programmes in southern Africa.

DDT (a chlorinated hydrocarbon) is still the most commonly used residual insecticide. However, the picture is changing with the availability and increasing affordability of alternative insecticides, especially synthetic pyrethroids with long residual activity. Concerns about the safety of DDT, will lead to their increased use and they are expected to eventually replace DDT as the insecticide of choice. Other new insecticide molecules (different groups) and formulations may also be available in the future that could be alternated with one another to form part of an insecticide resistance management (IRM) programme strategy. The inclusion of the synergist, piperonyl butoxide in novel, stable formulations may play a vital role in insect resistance management in the future as well as improve the lethal effect of the toxicant.

To ensure the best use of scarce health resources, chemical control must be targeted with the usage of sound epidemiological data i.e. the distribution and determinants of malarial disease within the human population. Control measures must be managed according to modern management processes i.e. planning, organisation, leadership and control.

Common problems associated with the use of insecticides in vector control programmes:

- Lack of information about the mosquito and its behaviour.
- Wastage of insecticides, due to unnecessary application.
- Community opposition due to the lack of insecticidal effect on non-target insects and the inconvenience during application.
- Lobbying by environmentally active pressure groups.
- Insecticide resistance.
- Certain social customs like regular re-plastering of surfaces in traditional homes.
- Limited residual activity of insecticides.
- Variety of different structures and substrate, which are sprayed.

Keys to successful chemical control

It is essential that the programme should be technically sound with due attention being paid to the:

- Biology and habits of the vector mosquito
- Procurement, safe handling and effective application of insecticides
- Appropriate training and supervision of staff

A clear plan of action, which includes evaluation of and proposed control interventions, must be prepared. Planning should be carried out within the resources available. The programme will only be sustainable if the control activities are well understood and acceptable to the community.

The development of mosquito resistance to insecticides can be limited by proper application: the "where", "when" and "how much" to apply. It is also important that the same class of insecticide and its formulation **is not used** against both larvae and adult mosquitoes as this can promote the resistance in the population.

Insect behaviour may also impact on the success of the spraying programme and should be constantly monitored, particularly if insecticide formulations or intervention methods are to be changed.

Larviciding

The objective of larviciding is to reduce the source of vector mosquito breeding in areas close to human activities. This is achieved by the application of insecticides to actual and potential mosquito breeding sites.

There are a number of different chemical formulations that are suitable for the control of mosquito larvae but in southern Africa, Temephos (organophosphate) is the larvicide most used for vector mosquito control and *Bacillus thuringiensis subsp. israelensis* (Bti), a specific, selective biological larvicide. Diflubenzuron and other insect growth regulators (IGR's) have also been proven to be highly efficient in preventing emergence of adults from the pupal stage. Larviciding is usually only considered in special situations, but it is time that its value in an integrated vector control programme be re-assessed. It may for example, be possible in many arid areas with limited permanent water bodies, to largely reduce "blanket" residual spraying by introducing larviciding coupled with "strip" spraying. The main disadvantage of chemical larviciding is that repeated applications are necessary. An advantage is the simultaneous reduction of nuisance mosquitoes that enhances community acceptance.

For detailed information on larviciding and larvae control through environmental management refer to the:

"Manual on larvae control operations in Malaria programmes" and
"Larval Source Management" published by the WHO.

Residual spraying

Indoor residual spraying is the most widely used method of vector control in malaria control programmes and is a valuable intervention

to prevent malaria transmission. The effectiveness of residual spraying depends on the timing of the spraying relative to the peak of transmission and rainy season, taking into consideration the residual effect of the insecticide that is applied.

Insecticides that are proven to have a long residual life are applied to a dwelling's surface. The formulations used are primarily particulate formulations i.e. wettable powders, wettable granules, suspension concentrates, capsule suspensions and micro-capsules. These products are mixed with water and applied to surfaces where the insects may alight. Once on the surface the water evaporates leaving a crystalline "particle" deposits on the target surface. On contact with the sprayed surface the mosquitoes absorb a lethal dose of the insecticide. Generally all walls, roofs and eaves of dwellings are sprayed. The underside of furniture is a potential resting place as are curtains and should also be sprayed.

The effectiveness of an indoor applied residual insecticide depends on:

- The resting behaviour of the particular vector mosquito
- The toxicity and period of effectiveness of the insecticide against the vector mosquito
- The effect of the insecticide on the resting behaviour of the mosquito
- The design of the dwelling and type of building material
- The correct application rate

In selecting a residual insecticide the biological activity against the mosquito vector and the safety of human beings, domestic animals and the environment as a whole, are primary considerations.

The following insecticides are currently considered suitable as residual sprays for vector control programmes in southern Africa:

Insecticide	Chemical type	Trade name
DDT	Organochlorine	DDT 75%WP
Alphacypermethrin	Synthetic pyrethroid	Fendona 10SC
Deltamethrin Deltamethrin/Piperonyl butoxide	Synthetic pyrethroid Synthetic pyrethroid/ synergist	K-Othrine WG250 Impact CS
Bendiocarb	Carbamate	Ficam WP
Lambdacyhalothrin	Synthetic pyrethroid	Icon 10 CS

As other potential insecticide are identified, tested, registered and approved these will be added to the list above.

CHAPTER: 2

marketing

THE APPLICATION OF RESIDUAL INSECTICIDES

Equipment for insecticide application

The Hudson X-Pert Compression Sprayer

Wefco Marketing International recommends the Hudson X-Pert Model 67422AD. This is a 15.1 litre sprayer (tank size) with a 10 litre working capacity. The additional 5.1 litres of headspace allows for adequate pressurization of the tank thereby reducing the number of re-pumps required to deplete the contents within acceptable average pressures. In addition to this, insecticide manufacturers offer unit dose sachets for accuracy and convenience, to be diluted in 10

litres water and applied to 200 or 250 m² of surface area.

Good quality reliable sprayers are essential for an effective spraying programme. The Hudson X-Pert compression sprayers are used globally in disease vector control programmes and are also the sprayer of choice in southern Africa. Reasons for this choice are that the Hudson sprayer:

- Is manufactured from stainless steel, is strong, durable and has been field proven for more than fifty years
- Has a large filling aperture and so facilitates easy cleaning and filling
- Has a reliable and accurate pressure gauge which is important as the correct pressures should be maintained throughout spraying
- Has an effective filtration system preventing blocked nozzles
- Has interchangeable hardened stainless steel nozzles if required

An added advantage is that spares for Hudson X-Pert sprayers are generally available.

* (The Hudson X-pert sprayer is the Patent of the H.D. Hudson Manufacturing Company, U.S.A. but is also manufactured by H.D Hudson Asia Ltd, a wholly owned subsidiary).

Nozzles

Standardised nozzles should be used throughout the spraying programme, although different types are necessary for different insecticides and for absorbent and non-absorbent surfaces.

The two nozzles used, are both of the flat fan type (TEEJET or similar) and differ only in their throughput per minute at 40 psi (276 kPa).

HSS 8002 / 8001 or HSS 8002E / 8001E nozzle tips

HSS = Hardened Stainless Steel

80 = 80° (angle of spraying fan)

02 = 0,2 US. gallons (757 ml) per minute

or

01 = 0,1 US. gallons (378 ml) per minute

E = Even (consistent uniform coverage requiring no overlapping of spray).

Sketch of spray-pattern and deposit achieved with an 8002 fan type nozzle.

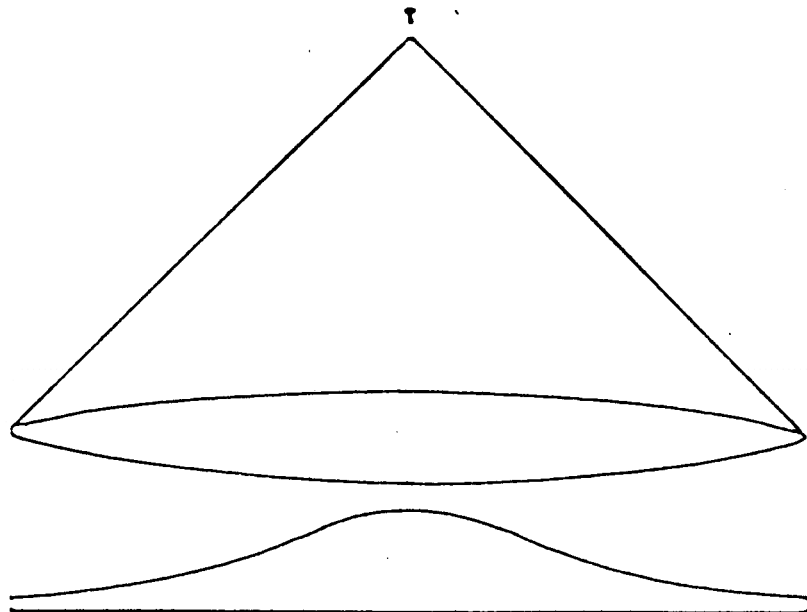
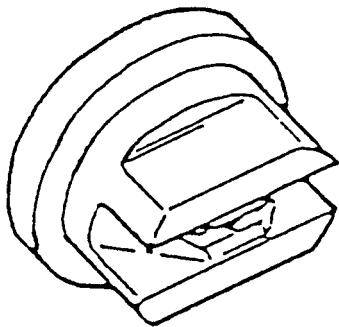

The 8002 nozzles are used for:

- the application of DDT
- the application of synthetic pyrethroids/carbamates on absorbent surfaces (mud, unpainted cement)

The 8001 nozzles are used for:

- the application of synthetic pyrethroids/carbamates on non-absorbent surfaces (smooth or painted surfaces)

Testing nozzles

Although the 8001/2 nozzle tips are manufactured from hardened stainless steel, the wettable powder (WP) formulations, especially DDT, commonly used in vector control programmes, is abrasive. The nozzle throughput, therefore, has to be checked on a regular basis to ensure economical and effective application.

Testing is simple and only requires a standard sprayer filled to the correct level (10 litres) with water at a pressure of 40 psi (276 kPa) and a 250ml measuring cylinder.

Firstly, check the nozzle for visible damage. Spray a wall or floor surface for a few seconds ensuring the nozzle is 45 cm from the target while observing the spray pattern. If there is a visibly altered spray pattern e.g. a narrower than normal swath, the nozzle must be discarded.

Next, ensure that the pressure in the sprayer is at 40 psi (276kPa). Spray into the measuring cylinder for exactly 15 seconds and measure the amount discharged into the measuring cylinder.

<u>8001/8001E</u>	<u>8002/8002E</u>	<u>Interpretation</u>
<u>102 ml.</u>	<u>205 ml.</u>	<u>Normal</u>
>102 ml.	>205 ml.	Worn but still serviceable
>112 ml.	>225 ml.	No longer serviceable Scrap-discard

Practical Operation of the Hudson X-pert sprayer

For detail instructions regarding maintenance, cleaning, fault finding and repair of compression sprayers refer to Chapter 4.

CLOSING THE TANK - Hold cover upright, insert into tank (Fig.1). Lift and seat in tank opening (Fig. 2). Turn handle across width of opening (Fig. 3).

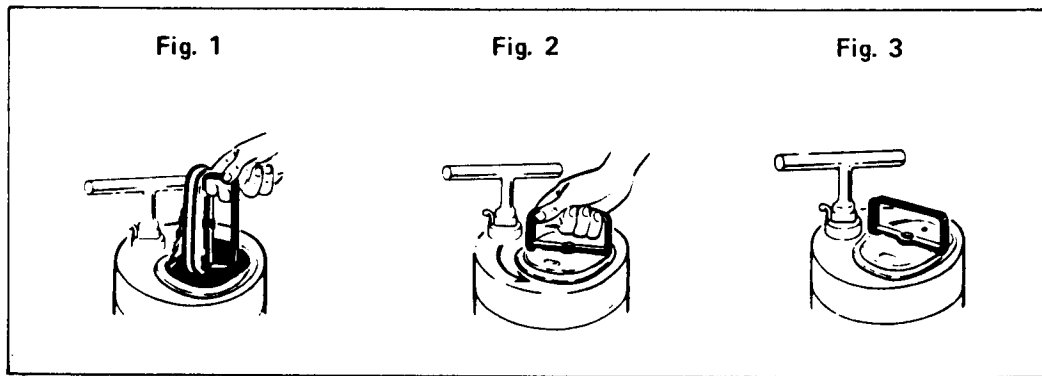

OPENING THE TANK - Turn handle on cover right or left so it depresses air release valve pin (Fig. 4). This opens air release valve on cover to reduce tank pressure (Fig. 5).

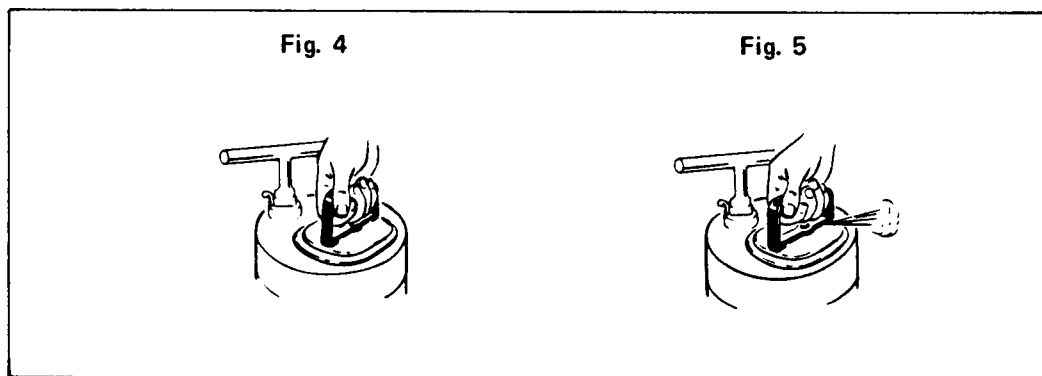

PRESSURIZING THE TANK - Unlock pump plunger by turning lever on pump cap A (Fig. 6). Using both hands, raise plunger to its "up" position. Then push plunger downward. Continue this action using full, even strokes - all the way up, all the way down.

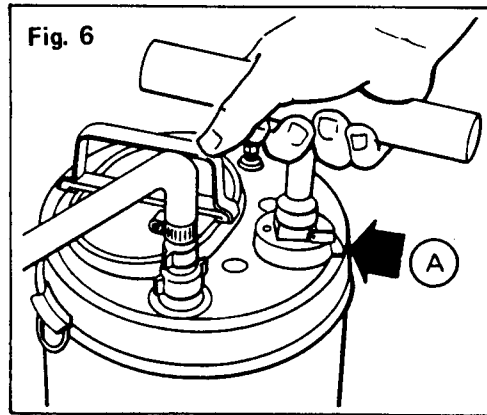

Maintain a pressure range of between 25 and 55 pounds (Fig. 7). Always release pressure when sprayer is not in use, particularly if left standing in a warm place or when it is being transported.

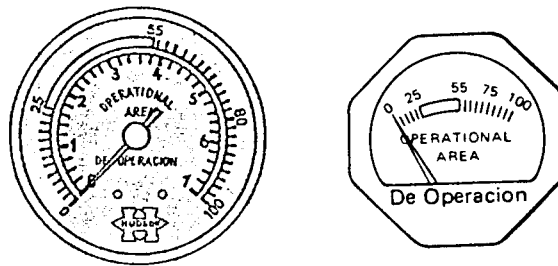
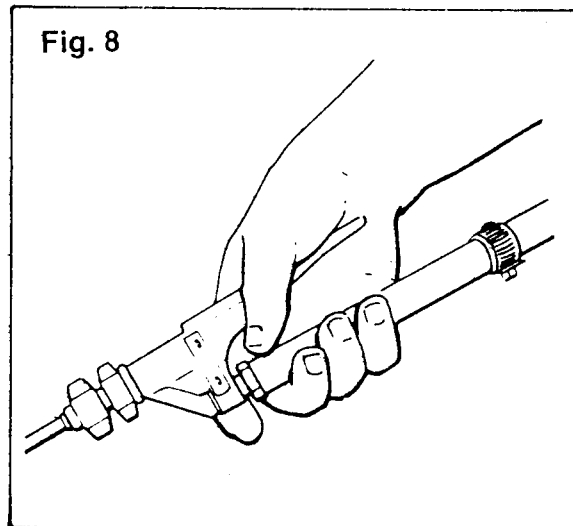

Fig. 7

SPRAYING - Squeeze handle of spray control valve to release spray material (Fig. 8).



CLEANING THE SPRAYER - Clean daily after spraying. Do not allow insecticide to stand in tank after use. To clean, first rinse sprayer out thoroughly with water. Then remove the nozzle. Add about 4 litres of fresh water to the tank; pressurize sprayer and flush water through system. Release tank pressure. Drain the discharge assembly by holding it pointed downwards with spray control valve open. Drain tank and wipe interior wall.

After flushing through, remove strainer at control valve (Fig. 9).

NOTE: To remove strainer from valve, grasp it at its base, not by its screen. The strainer has a bayonet connection, not a thread; twist strainer slightly as you pull it out. Rinse and clean strainer with water.

Clean all residue from inside surface of nozzle cap by washing or flushing out under running water (Fig. 10).

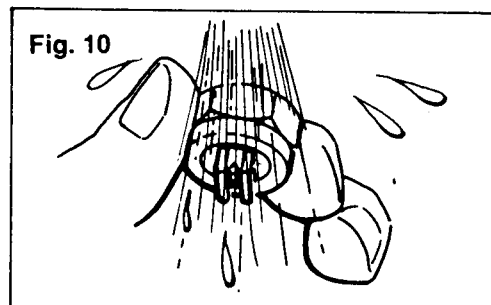
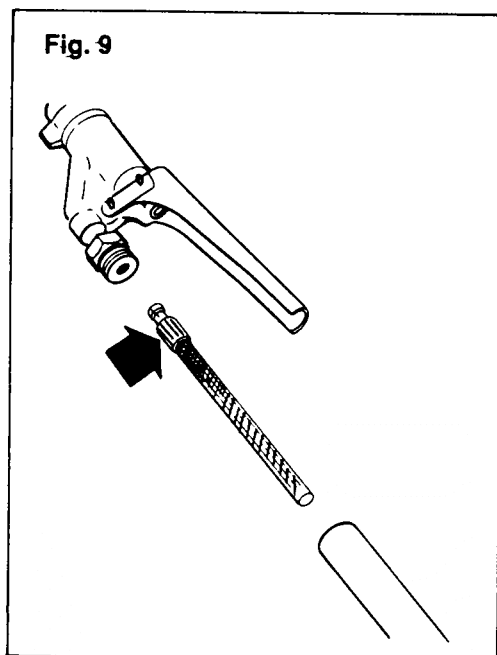

Reassemble the parts. Hang tank upside down with cover open. Allow discharge to hang downwards, keeping valve open by tying lever down with string (Fig. 11).

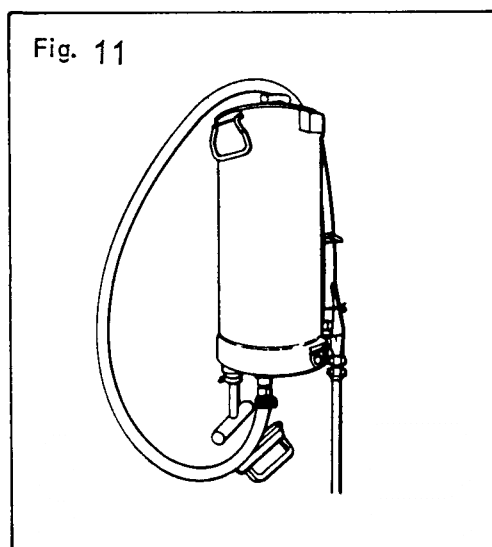

STORAGE - Before storing for a period of weeks or months, each sprayer should be completely disassembled and all parts cleaned and dried. The plunger cup leather must be well oiled. Lightly oil threaded fittings.

Oil and aromatic solutions must never be used on the rubber or plastic components of the sprayer.

When removing sprayer from storage, check thoroughly to be sure that

it is in good operating condition.

SERVICING -

NOTE: If sprayer is pressurized, release air pressure before servicing.

IF PUMP DOESN'T BUILD PRESSURE - In most instances, failure of the pump to build air pressure in the sprayer is due to a dry or worn out plunger cup leather. To work on cup leather, always remove plunger from pump cylinder. Do not attempt to oil cup leather through breather hole in pump cap.

First, unthread pump cap A (Fig. 12). If cap is too tight, and if pump will build even slight temporary pressure, pressurizing the tank will make it easier to loosen cap. Once cap is loosened, release tank pressure. Hold pump cylinder by inserting hand through tank filler opening (Fig. 13), and unscrew cap all the way. Pull plunger from cylinder, and remove cylinder from inside the tank.

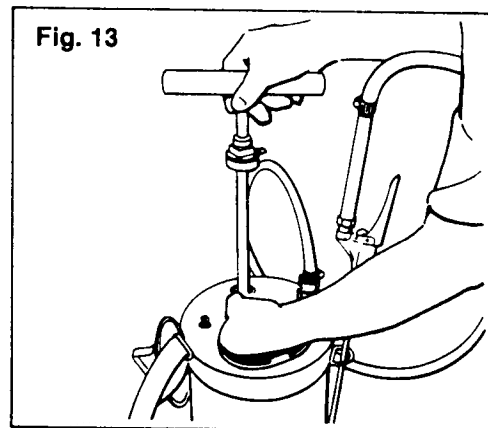
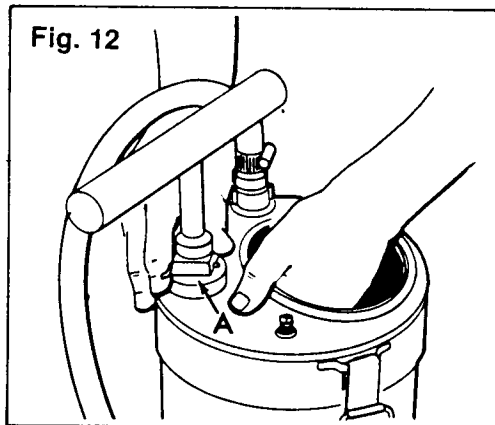

Place a few drops of clean oil (not heavier than SAE 30) on leather, and massage until it is soft. Replace plunger cup leather if it is damaged (Fig. 14). To remove plunger leather assembly, use a coin rather than a screwdriver.

To reassemble pump cylinder into the tank, care must be taken that the squared edge of the flange at the top of the cylinder is aligned with the tank wall when it is inserted (Fig. 15). Turn plunger cap *counter clockwise* on cylinder to mate threads and then turn pump cap clockwise until finger tight.

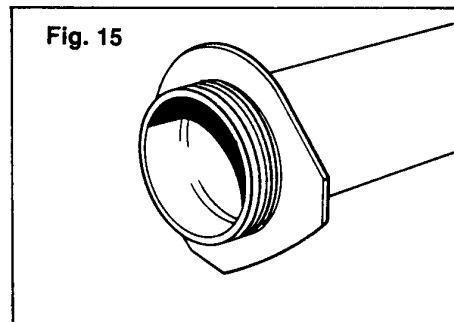
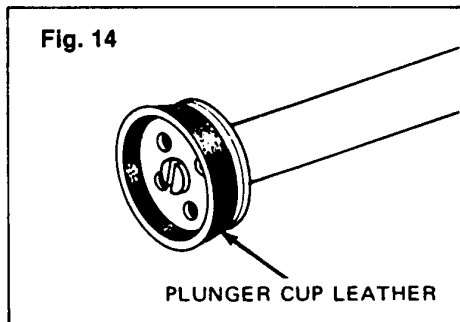

~~IF SPRAYER DOESN'T SPRAY~~ - If, when under pressure, spray stops, becomes erratic or significantly decreases, look for the cause of the problem in the discharge line.

Release pressure, then clean the nozzle (Fig. 16). Use broom straw or sliver of wood to clear orifice if plugged. **Do not use wire.**

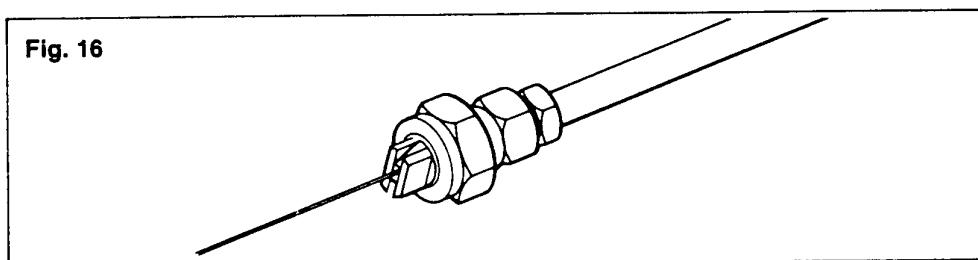

Check strainer A at spray control valve by unthreading strainer housing B (Fig. 17). Strainer has a bayonet connection and is removable by hand; twist it slightly as you pull it out.

Always grasp base - never grasp screen section.

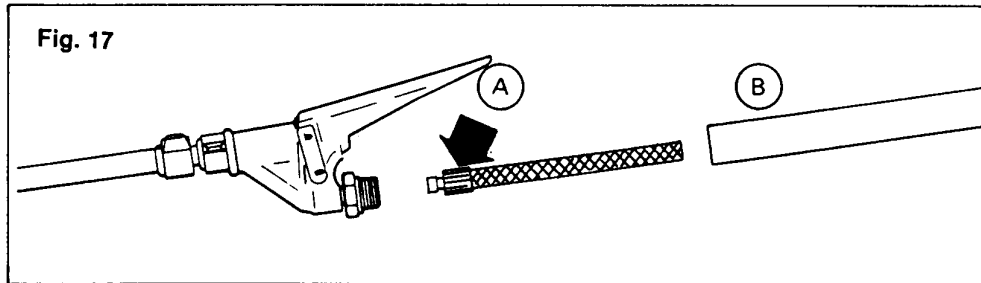

IF SPRAYER DOESN'T SEAL AGAINST PRESSURE - Check tank cover gasket A (Fig. 18)

Check pump cylinder gasket B (Fig. 19).

(See *IF PUMP DOESN'T BUILD PRESSURE*, on how to remove pump cylinder.)

Clean seating surfaces. Replace gaskets if necessary.

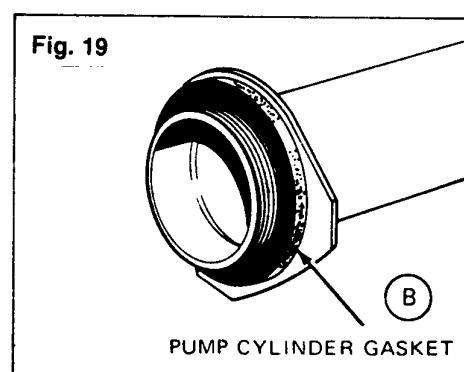
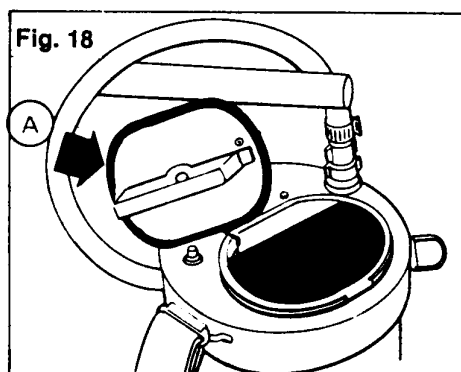

IF SPRAYER DOESN'T SHUT OFF - Depressurize the sprayer, and disconnect spray control valve from hose by unscrewing at strainer housing. Remove strainer and extension tube.

Remove cotter pins (A Fig. 20). Unthread winged valve body Cap B, maintaining a firm grip on cap and valve body. Clean, check and if necessary, replace valve seat in cap B, O-ring, spacer, washer, and valve pin packing. Assemble all elements on valve pin, press pin back into valve with cap B, tighten cap B and replace pins A.

TIGHTENING FITTINGS - **All** fittings for most general servicing can be tightened or loosened by hand. If they become dry and hard to turn, add a drop of oil to the threads of cap B (Fig. 20).

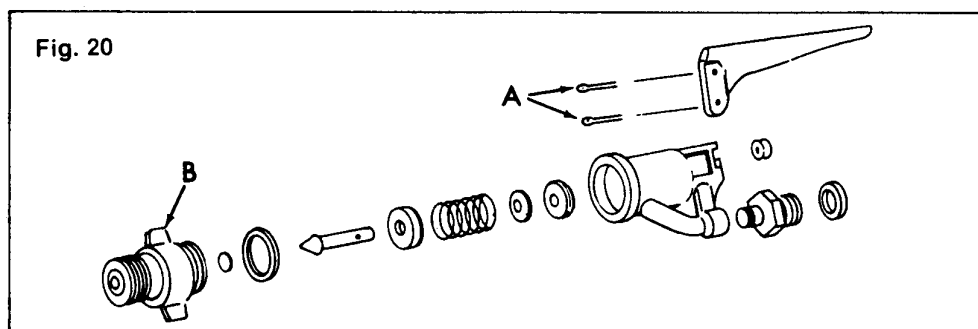

WHEN TRANSPORTING EMPTY SPRAYER - To carry sprayer, first release all pressure. Keep cover locked in position or hanging outside of tank. Do not let cover hang inside tank where it can strike and possibly damage the pump cylinder.

CHECKING FOR AIR LEAKS - If air leaks cannot easily be located, test fittings by applying a soapy solution and observing for bubbles.

SPRAYER ASSEMBLY (Hudson X-Pert)



wefco

m a r k e t i n g

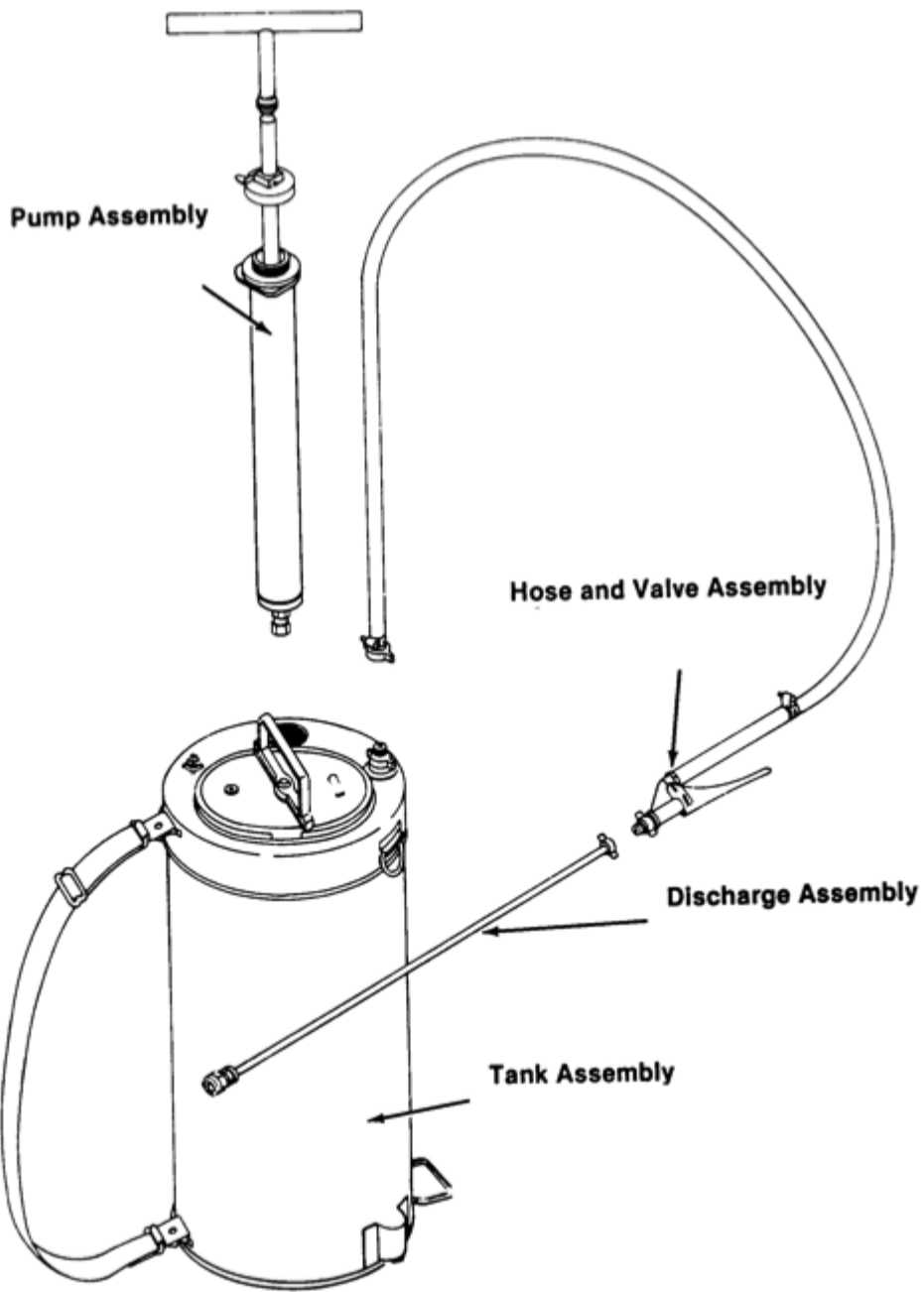

TANK SERVICE PARTS (Hudson X-Pert)

wefco

marketing

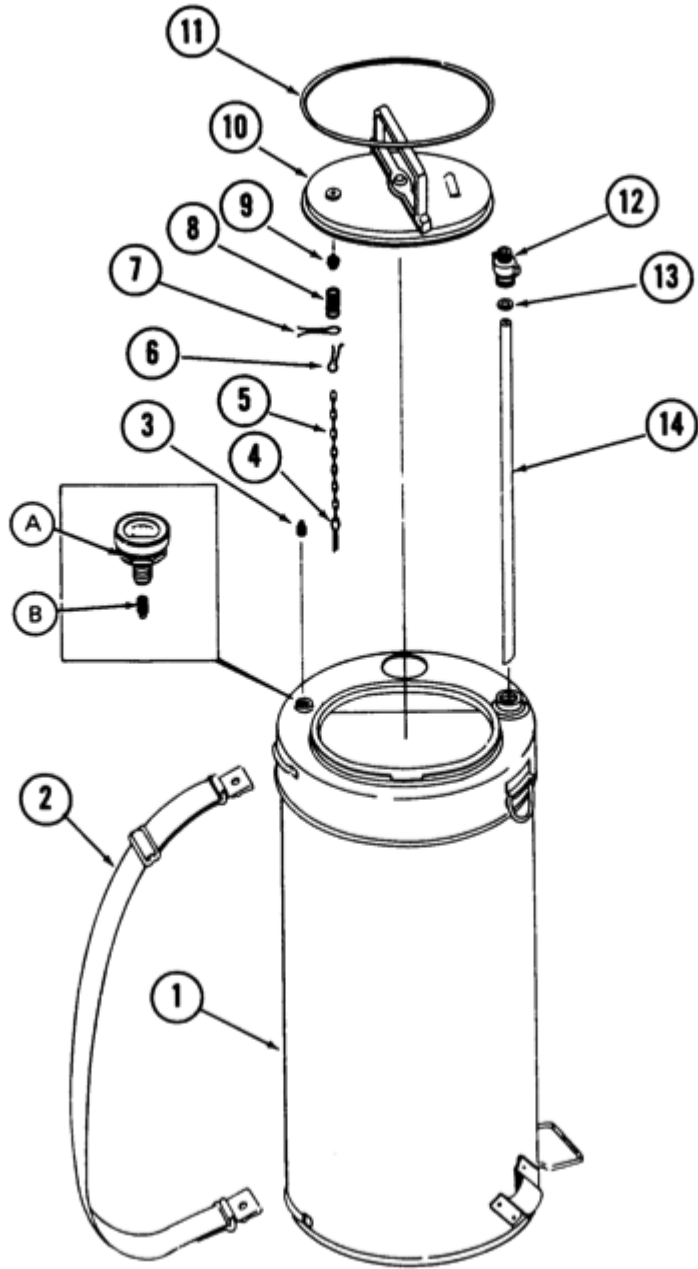

PARTS LIST

Ref. No.	Part Number	Description
1	142-612	Spare Tank Only, less cover, 3 gallons
	142-615	Spare Tank Only, less cover, 4 gallons
2	152-829	Shoulder Strap, 2" Wide
3	114-152	Plug for gauge adaptor fitting on top
4	801-423	1/8 x 1/2 Cotter Pin
5	116-426	Cover Chain
6	801-411	3/32 x 1/2 Cotter Pin
7	801-419	3/32 x 7/8 Cotter Pin
8	150-605	Valve Pin Spring
9	143-000	Valve Pin Assembly
10	140-205	Cover Assembly, complete
11	151-401	Cover Gasket
12	115-965	Male Fitting
13	805-312	O Ring, for dip tube
14	129-074	Dip Tube Only, for 3 gallon tank
	129-075	Dip Tube Only, for 4 gallon tank
OPTIONAL ITEMS		
PRESSURE GAUGE ASSEMBLY		
A	803-311	100-lb. Pressure Gauge
B	146-605	Filter Assembly, for pressure gauge
NOZZLE FLOW REGULATOR		
	148-000	Nozzle Flow Regulator; regulator and gaskets
	148-001	Nozzle Flow Regulator Kit; includes 153-400E nozzle tip
SHUTOFF COCK		
C	148-704	Hose Adaptor Assembly
D	115-960	Hose Adaptor
E	806-428	Shutoff Cock
F	115-968	Dip Tube Adaptor, with wing fitting
PRESSURE REGULATOR		
1	148-958	Pressure Regulator Assembly, complete with hose adaptor and dip tube adaptor
2	115-466	Regulator Body Cap
3	115-467	Pop-Off Body Cap
4	115-476	Pop-Off Spring Cap
5	115-477	Regulator Spring Cap
6	115-486	Adjusting Screw
7	115-490	Regulating Valve Pin
8	115-517	Adjusting Screw Locknut
9	115-780	Regulating Valve Pin Adaptor
10	115-806	Valve Body
11	115-960	Hose Adaptor
12	125-986	Regulator Diaphragm
13	150-406	Pop-Off Spring
14	150-407	Regulating Spring
15	150-612	Regulating Valve Pin Spring
16	152-051	Pop-Off Rubber Diaphragm
17	805-309	Regulating Valve Pin Adaptor Gasket
18	115-968	Dip Tube Adaptor



PUMP AND CYLINDER SERVICE PARTS (Hudson X-Pert)

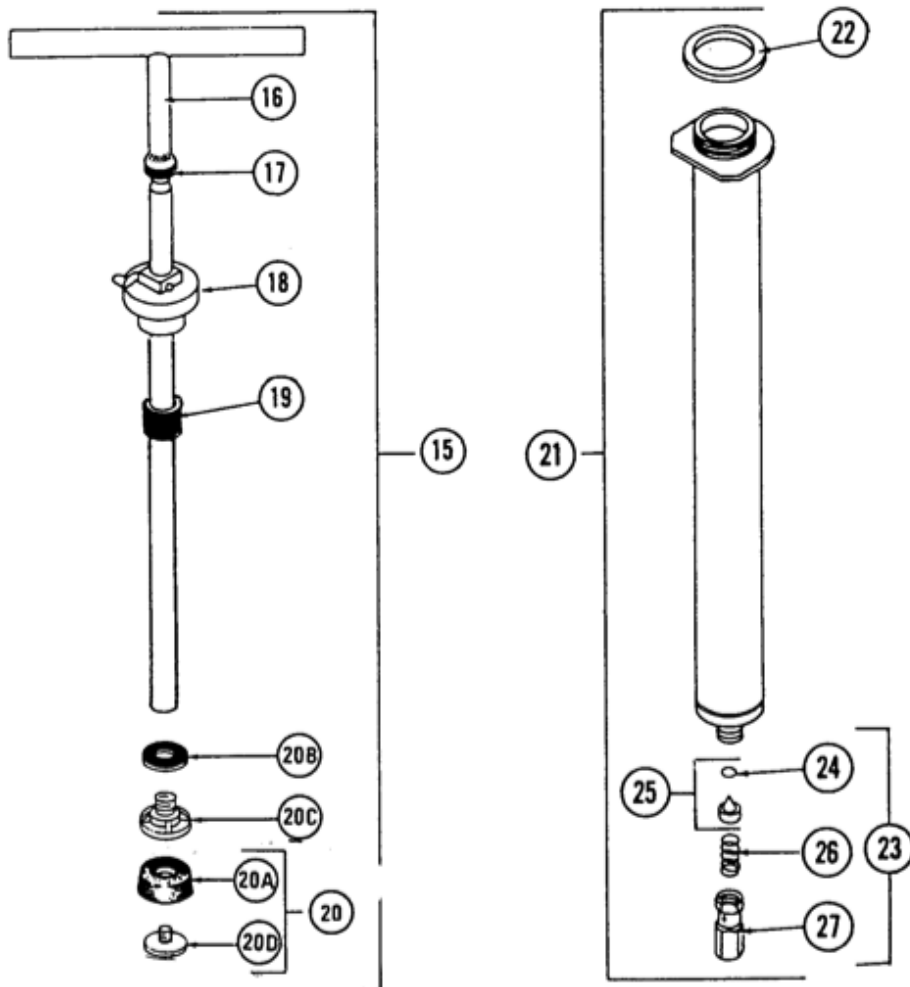

Ref. No.	Part Number	Description
15	147-541	Plunger Assembly, complete
16	147-501	Plunger Tube and Handle, only
17	151-028	Bumper Pad
18	149-100	Pump Cap Assembly, only
19	115-842	Bumper Pad
20	148-833	Cup Replacement Kit
20A	154-007	Cup Leather Only
20B	123-908	Washer
20C	153-812	Plunger Adaptor
20D	153-816	Cup Retainer
21	147-202	Pump Cylinder Assembly, complete
22	151-030	Pump Cylinder Gasket
23	140-055	Pump Cylinder Check Valve Assembly, complete
24	805-401	O Ring, for pump cylinder check valve
25	140-054	Pump Cylinder Check Valve Assembly
26	150-604	Spring, for pump cylinder check valve
27	110-790	Housing, for pump cylinder check valve

EXTENSION TUBE AND NOZZLE SERVICE PARTS (Hudson X-Pert)

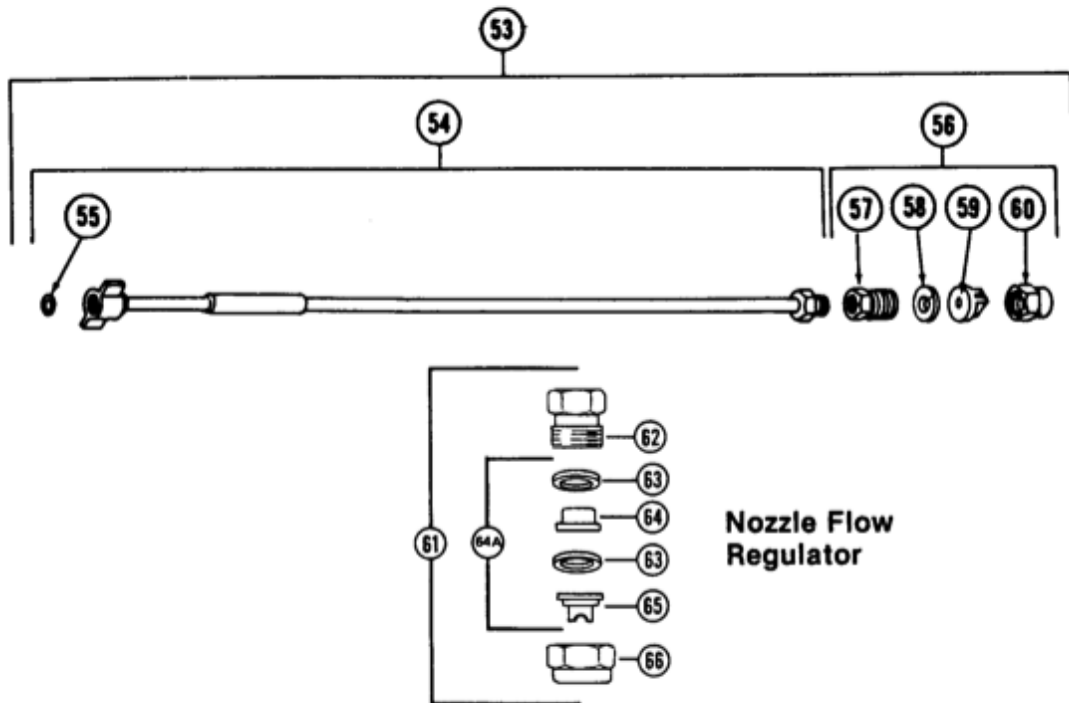

**Nozzle Flow
Regulator**

Ref. No.	Part Number	Description
53	141-966	Extension Tube and Nozzle Assembly for 3 Gallon Unit
	141-972	Extension Tube and Nozzle Assembly for 4 Gallon Unit
54	141-967	3 Gallon Extension Tube Assembly Only
	141-971	4 Gallon Extension Tube Assembly Only
55	805-337	O Ring Gasket for Extension Tube
56	141-989	Nozzle Assembly Complete
57	114-791	Nozzle Body
58	123-950	Polyethylene Nozzle Gasket
59	805-855	No. 8002HSS Hardened Stainless Steel Nozzle Tip
60	115-680	Nozzle Body Cap
61	141-983	Nozzle Flow Regulator Assembly. Consists of 114-791 Nozzle Body, 123-950 Gasket (uses 2), 148-000X Nozzle Flow Regulator, 153-400E Nozzle Tip and 115-680 Nozzle Body Cap.
62	114-791	Nozzle Body
63	123-950	Nozzle Gasket, Polyethylene
64	148-000X	Nozzle Flow Regulator
64A	148-001	Nozzle Flow Regulator Kit. Consists of 123-950 Gasket (uses 2), 148-000X Nozzle Flow Regulator (2), 153-400E Nozzle Tip.
65	153-400E	Hardened Stainless Steel Nozzle Tip
66	115-680	Nozzle Body Cap



watermark marketing

HOSE AND VALVE SERVICE PARTS (Hudson X-Pert)

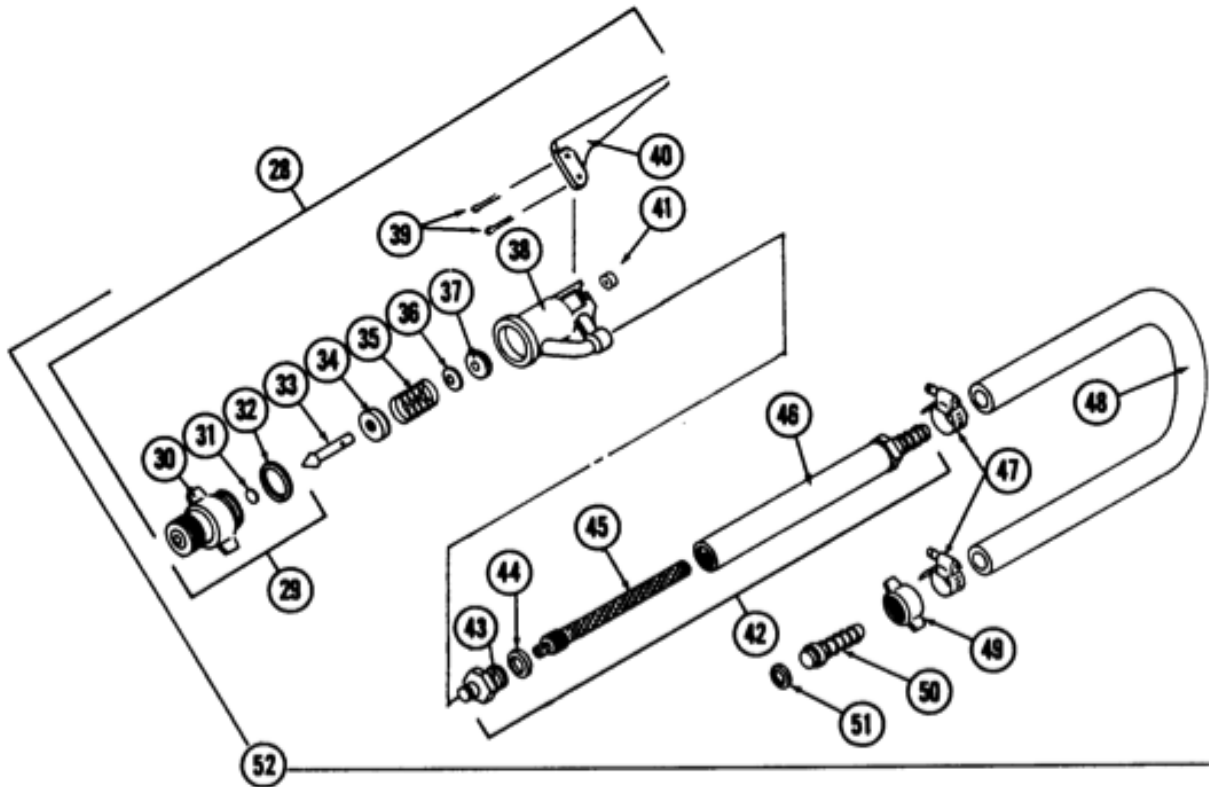

Ref. No.	Part Number	Description
28	149-706	Shutoff Assembly, complete, thrustless
29	149-702	Valve Body Cap with O ring gaskets
30	115-733	Shutoff Valve Body Cap
31	805-335	Valve Body Cap O Ring, for valve pin
32	805-309	Valve Body Cap O Ring
33	115-716	Shutoff Valve Pin
34	110-243	Teflon Valve Pin Spacer
35	150-400	Shutoff Valve Pin Spring
36	123-911	Shutoff Valve Pin Washer
37	151-016	Shutoff Valve Pin Packing
38	153-377	Shutoff Valve Body
39	801-423	1/8 x 1/2 Cotter Pin
40	123-899	Shutoff Operating Lever
41	110-234	Teflon Bearing, for valve pin
42	146-617	Strainer Assembly, complete
43	114-905	Male Fitting, for strainer housing
44	805-310	O Ring Gasket, for male strainer fitting
45	152-356	Strainer Assembly
46	146-627	Strainer Housing Assembly
47	803-623	Hose Clamp
48	115-902	Hose Only
49	115-970	Nut
50	115-950	Hose Connector
51	805-307	O Ring Gasket, for hose connector
52	146-689	Hose, with Thrustless shutoff and strainer assembly

APPLICATION OF INSECTICIDES

Insecticide must be applied at a specific uniform dosage on all sprayed surfaces. It is therefore important that application rates are accurately calculated.

Application of DDT 75% WP

DDT, as it is formulated in the factory, consists of 75% active ingredient (a.i.) and 25% carrier. For mosquito control, a 5% solution is required. To achieve this, 670 gram 75% DDT (containing 502 gram (a.i)) is dissolved in 10 litres of water. When spraying, the operator must keep the pressure between 25 psi (172kPa) and 55psi (380kPa).

At an average pressure of 40psi (276kPa), the throughput (discharge) of an 8002 nozzle is 757 ml per minute of suspension that contains 38 gram of a.i., enough to cover 19m² per minute. To achieve this, the operator sprays at a speed of 2,2 seconds per linear meter, while keeping the nozzle 45cm from the surface being sprayed. This gives an effective spray width of 70cm after allowing for a 5cm overlap (8002 Nozzle) and an application of 2 gram a.i. DDT per m² which is an effective killing dose.

670 gram of 75%/DDT = 502 gram of 100%/DDT

Mixed in 10 litres of water = a 5% solution

Nozzle throughput = \pm 757ml of solution per minute

i.e. 38 gram 100% DDT per minute

Which must cover 19m sq per minute

Effective swath width of nozzle = 70cm with nozzle 45cm from wall

A spray speed of 2,2 seconds per linear meter will give 2 gram a.i. (100%) DDT per m sq.

Application of Pyrethroids

K-Othrine WG 250 (Deltamethrin)

K-Othrine WG 250 is supplied in 20 gram sachets in a concentration of 25% a.i (250g/kg).

The target dosage rate is **20 mg a.i. m²**. For non-absorbent surfaces 2 sachets must be mixed in 10 litres of water and applied to 500 m² through an **8001/8001 E** nozzle following the same procedure as for DDT.

For absorbent surfaces, e.g. mud, concrete, cement, mix 1 sachet in 10 litres of water and apply to 250 m² through an **8002/8002E** nozzle following the same procedure as for DDT.

ICON 10CS (Lambda cyhalothrin)

ICON 10CS is supplied in 62.5 ml sachets in a concentration of 10% a.i (100g/l).

The target dosage rate is **25 mg a.i. per m²**. For non-absorbent surfaces 2 sachets must be mixed in 10 litres of water and applied to 500 m² through an **8001/8001E** nozzle following the same procedure as for DDT.

For absorbent surfaces, e.g. mud, concrete, cement, mix 1 sachet in 10 litres of water and apply to 250 m² through an **8002/8002E** nozzle following the same procedure as for DDT.

IMPACT CS (Deltamethrin & Piperonyl butoxide)

IMPACT CS is supplied in an 85 ml sachets in a concentration of 3% a.i. deltamethrin (30g/lt) and the synergist piperonyl butoxide at 15% a.i.(150g/l).

The target dosage rate is **20 mg a.i. per m²**. For non-absorbent surfaces 2 sachets must be mixed in 10 litres of water and applied to 250 m² through an **8001/8001E** nozzle following the same procedure as for DDT.

For absorbent surfaces, e.g. mud, concrete, cement, mix 1 sachet in 10 litres of water and apply to 125 m² through an **8002/8002E** nozzle following the same procedure as for DDT.

Application of Carbamates

FICAM (BENDIOCARB)

Ficam WP is supplied in a 125 gram sachet in a concentration of 80% a.i (800g/kg).

The target dosage rate is **400 mg a.i. per m²**. For non-absorbent surfaces 2 sachets must be mixed in 10 litres of water and applied to 500 m² through an **8001/8001E** nozzle following the same procedure as for DDT.

For absorbent surfaces, e.g. mud, concrete, cement mix 1 sachet in 10 litres of water and apply to 250 m² through an **8002/8002E** nozzle following the same procedure as for DDT.

NOTE

The reason for using 8001 nozzles for spraying pyrethroids/carbamates on non-absorbent (painted) surfaces is to obviate the problem of run-off. Although the throughput of the nozzle is half that of the 8002, the target dose is achieved by increasing the insecticide concentration. Irrespective of the nozzle that is used, spraying speed and other procedures remain the same thereby facilitating the training of spray men.

It is an important responsibility of the supervisor to determine the correct concentration of insecticide, nozzle type and ensure correct application.

CHAPTER 3

TRAINING SPRAY MEN

Time required for training

To train spray men with no previous experience, requires a week. Approximately 6 hour per day should be allocated towards familiarising spray men regarding:

- Malaria, its transmission and how it is controlled
- insecticides: Environmental hazards
 Toxicity / first aid
 Safe handling and disposal
 Use and care of protective clothing
- Organisation of the control programme
- Duties to be performed
- Government regulations covering salaries, working hours
etc.
- Discipline and supervisory aspects and

- Health education

Introduction

To achieve a uniform deposit of insecticide, spray men must be adequately trained.

The amount of insecticide deposited is determined by:

- The concentration of the insecticide in the liquid sprayed (wash) and
- The nozzle which is used.

These two factors are constant in the programme.

- The pressure at which the liquid will be applied
- The distance between the nozzle and the surface to be sprayed
- The velocity / rhythm / speed with which the spray man works

*These must be uniform throughout spraying programmes and are entirely in the hands of the spray man. **His efficiency will depend on the quality of the training he receives.***

Spraying done correctly is the backbone of an efficient vector control programme.

Spraying in the field often presents difficult situations or special cases which may not have been explained to the spray men during their training. A guiding principle is "**WHEN IN DOUBT, SPRAY**"

Equipment and materials required for training

- A sprayer for each trainee
 - A bucket and strainer for each trainee
 - Tools to disassemble sprayers for each group of trainees
 - A supply of water
 - Paint, preferably black and red
 - A three (3) meter tape measure
 - A wall 2 or 3 metres high and preferably 8 metres long for spraying practice
-
- 2 calendars or pieces of cardboard to simulate pictures
 - Several wooden boxes of different sizes to simulate furniture
 - A stopwatch or watch with a seconds function
 - Wooden dowels 60cm long to attach to the lance (extension) of each sprayer.
 - Appropriate personal protective/safety clothing.

Preparation of the training area

It is advisable to select a wall on which permanent lines can be painted for future training / refresher courses.

Figure 1: Method of marking wall for spraying practise

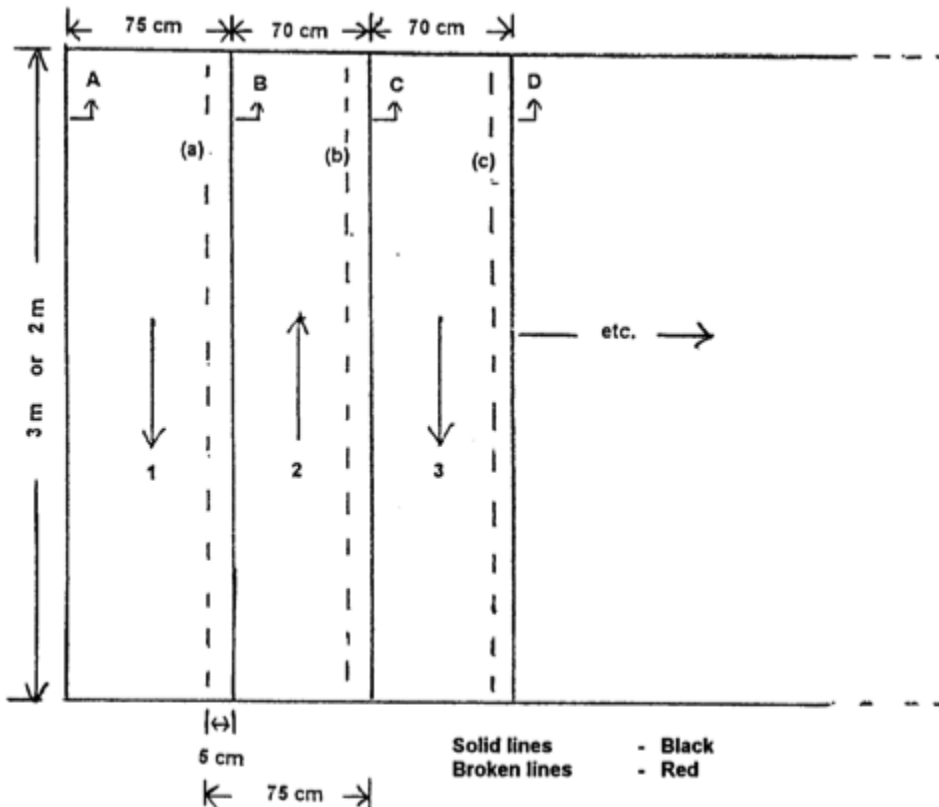

A wall of 3m high is preferable, but one of 2m can also be used (A height of 3m is useful because field observations have shown that a spray man of average height can spray up to 3m high with a standard extension when the nozzle is held 45cm away from the surface to be sprayed).

The number of swaths should be 9 (for a 3m high wall). This is, however, not critical because the surface area covered is calculated at a spraying speed of 2,2 seconds per linear metre.

The first 2 solid vertical lines A + B are painted 75cm apart. The first swath is therefore 75cm wide, which is the width of spray obtained with a 8002 nozzle under a pressure of 40 psi (276kPa) when it is 45cm away from the surface being sprayed.

A broken (dotted) line (a) is painted 5cm inside the second solid line B. This represents the overlap that must be maintained between consecutive swaths when spraying. Note: 'E' nozzles do not require overlapping of spray. Reference Chapter 2 – Nozzles.

The third and following solid lines are painted 70cm apart with a

broken (dotted) line (b), (c), etc. 5 cm inside each solid line **excluding the last one.**

To indicate the direction of spraying, arrows are painted in the centre of each swath - the first swath down, the second up, the third down, etc.

Step-by-step Spraying Training

Spray men should be encouraged that it is not difficult to be successful if they follow the procedures correctly and conscientiously.

It is also important that during all training exercises, the sprayer must be filled with 10 litres of water so that spray men become accustomed to carrying and handling this weight.

SHAKE THE SPRAYER WELL BEFORE AND REGULARLY DURING USE

CLEAN THE SPRAYER PROPERLY AFTER USE

During training, the sprayer must be cleaned every day, under supervision, in the same way as if insecticide had been used.

SAFE HANDLING, MIXING, APPLICATION AND DISPOSAL OF INSECTICIDES MUST BE A PRIORITY AND INTEGRAL THROUGHOUT TRAINING AND EVERYDAY

CARRYING AND HANDLING OF SPRAYER

- Demonstrate how to handle the sprayer.
- Demonstrate the tank cover operation. Explain that it seals when sprayer is pressurised.
- Spray men must practice what has been demonstrated.
- Demonstrate how to fill sprayer with water up to the 10 litre mark. Use strainer although insecticide is not being used. Explain why not to fill the sprayer to the top. Do not pressurise the sprayer at this stage. Spray men must practice filling the sprayer.
- Demonstrate how to withdraw lance and how to replace it in its support. Spray men to practice.
- Demonstrate the correct method of carrying the sprayer. The carrying strap must be over the left shoulder, the top of the sprayer forward with left hand grasping the pump handle. In this position, the spray man can easily check the pressure at regular intervals and agitate the contents of the sprayer. This position also allows for easy handling in confined areas.
- Practice adjusting the carrying strap so that it is comfortable for the spray man.
- Explain the importance of caring of the nozzle. Never use a pin, wire or other metal instruments to open blocked apertures as it may damage the nozzle thus affecting the discharge rate and shape and pattern of the spray fan.

- Explain the importance of agitating the contents of the sprayer (A Wettable Powder (WP) will settle at the bottom of the sprayer if this is not done).

CLEANING THE SPRAYER

- Explain how the sprayer operates under pressure. Detach the pump from the sprayer and demonstrate its similarity to a bicycle or car pump. Demonstrate how to apply pressure.
- Explain the function of the following when the sprayer is pressurised:
 - The air cushion
 - The pressure gauge
 - From the dip tube to the nozzle tip
 - Pressure release valve on the tank cover
- Dismantle the discharge line, remove the dip tube and explain the function of the following:
 - Dip tube
 - Discharge hose
 - Strainer in shut-off assembly
 - Shut-off operating lever
 - Extension tube (Lance)
 - The nozzle
- Re-assemble the sprayer

Steps in cleaning the sprayer:

Place the lance in its support.

Pour 2 - 3 litres of water into the sprayer, fit the tank cover, agitate, remove tank cover and pour out.

Again pour 2 - 3 litres of water into the sprayer, fit the tank cover, pressurise to 20 psi

Remove nozzle and keep it in a safe place.

Press shut-off operating lever and spray out the water.

Remove strainer from shut-off assembly, clean by agitating in water, also the nozzle - keep washed parts in a safe place.

Remove surplus water from tank and check for cleanliness.

Wash again if necessary

Replace strainer and nozzle, insert lance in its support.

Check tank cover gasket. Keep tank cover hanging inside tank to avoid loss of gasket.

Store in a safe place.

Trainees must practice procedures as above.

**ALL WASH WATER MUST BE DISPOSED OF (IN THE PRESCRIBED MANNER).
REFER TO THE GUIDELINES ON SAFE HANDLING OF PESTICIDES**

(Although the water at this stage will not be contaminated with insecticides, the trainees must get accustomed to this very important procedure)

MAINTAINING THE CORRECT DISTANCE BETWEEN THE NOZZLE TIP AND THE SURFACE TO THE SPRAYED.

- Attach the wooden extension to lance as in sketch below. This assists trainees to learn the correct distance (45 cm) between the nozzle tip and the wall.

WOODEN EXTENTION FOR LANCE

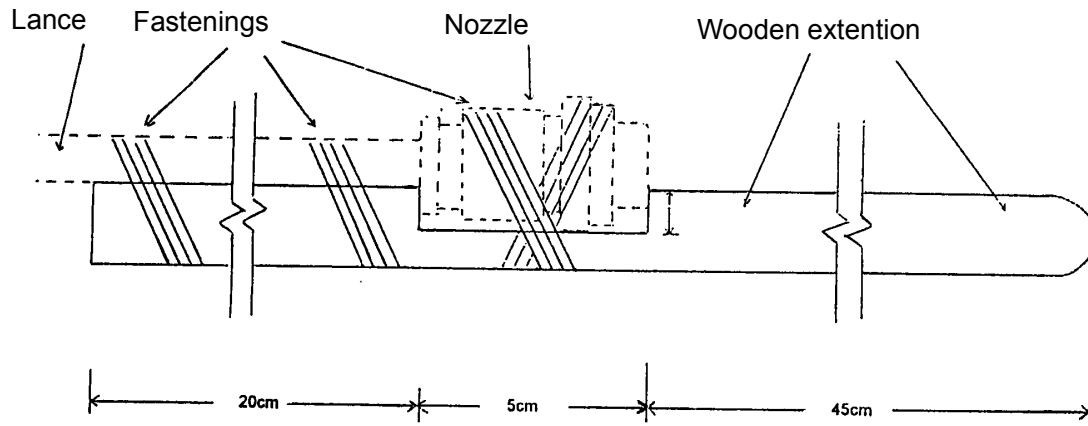

- Fill sprayer to the 10 litre mark and close tank cover. No pressure is applied at this stage.
- Assume spraying position facing the wall. The extended lance and lower arm must be in a straight horizontal position, forming a right angle with the upper arm at the elbow and the tip of the wooden extension must almost touch the wall surface.

This is the middle position of the swath (Position B)

- Move hand so that the tip of the wooden extension gradually move vertically upwards, at all times almost touching the wall surface, until the arm is fully extended.

This is achieved without change in standing position

The elbow is now completely straight and the tip of the wooden extension keeps the nozzle at 45 cm from the wall surface.

This is the upper position of the swath (Position A)

- Move the hand so that the tip of the extension moves vertically downwards, almost touching the wall surface, until it reaches the lower end. The elbow is now straight or almost straight, again.

This is the lower position of the swath (Position C)

- For practice, spray men must now move from the Upper position, through the Middle position to the Lower position. Repeat again from Lower position, through Middle position to Upper position.

SKETCH: *Maintaining the correct distance between the nozzle tip and the surface being sprayed.*

wetco
marketing

SKETCH: *Maintaining the correct distance between the nozzle tip and the surface being sprayed.*

- A . Upper position .
- B . Middle position.
- C . Lower position.

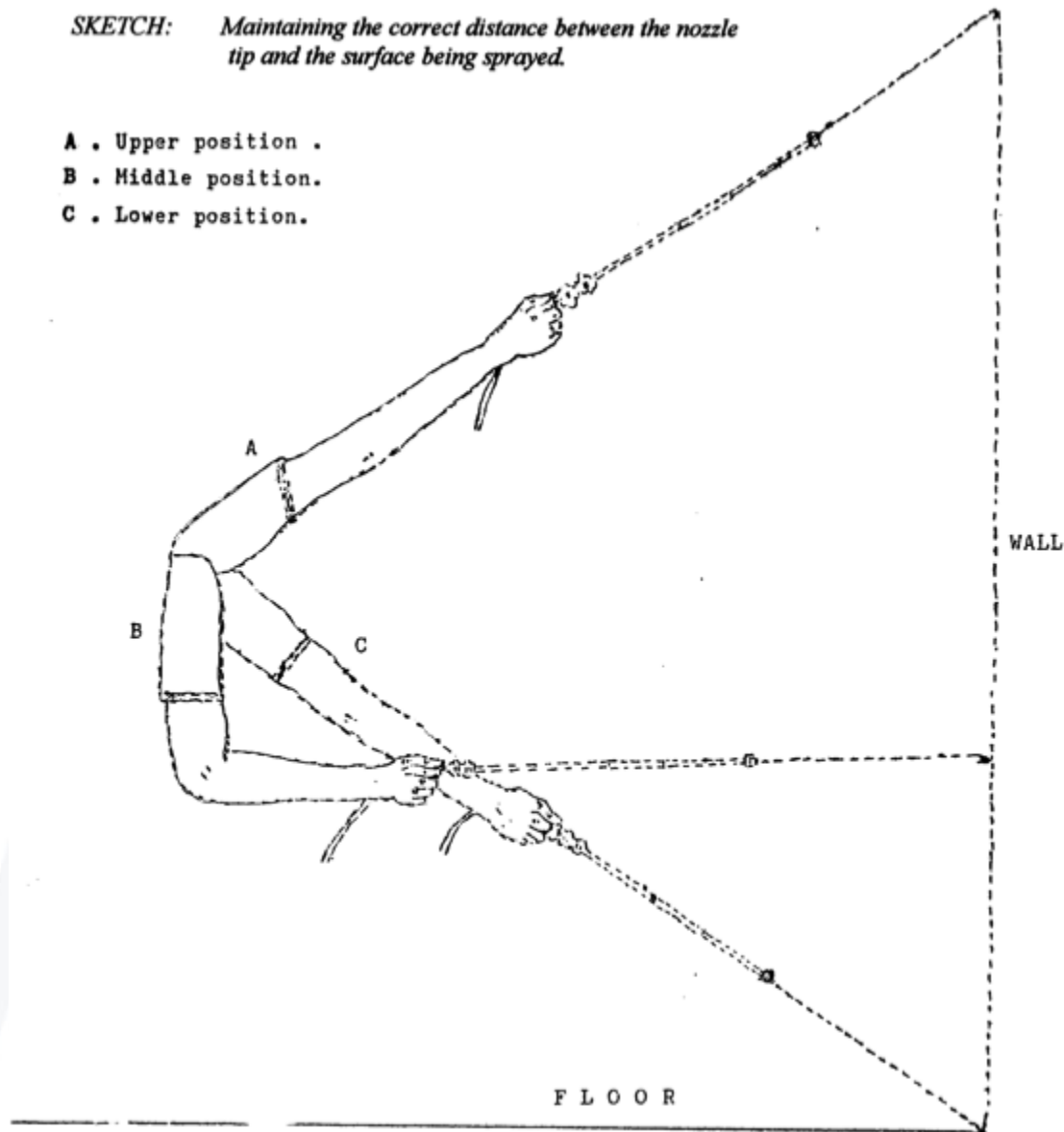

RHYTHM / VELOCITY / SPEED OF SPRAYING

NOTE: This exercise and calculations are in respect of the application of DDT 75 % WP. The training (speed, etc) is, however, the same for applying alternative insecticides although the throughput of the nozzle might be reduced and the concentration of the insecticide will be different.

- The TEEJET HSS 8002E nozzle has a throughput of 757 ml. per minute at a pressure of 40 psi.

- To apply this at the required rate, an area of 19 m² must be covered in one minute (27 linear meters).
- At this application rate, the following exercises provides practice in the correct speed at which the nozzle must move, at a distance of 45 cm. from the surface, a swath width of 75 cm. is achieved. On the outside edges of the swath, slightly less DDT is deposited with an 8002 nozzle therefore a 5 cm. overlap between successive swaths is required. An overlap is not required with the 8002-E nozzle.

SKETCH: Pattern of fan shaped spray from a TEEJET HSS. 8002 Nozzle

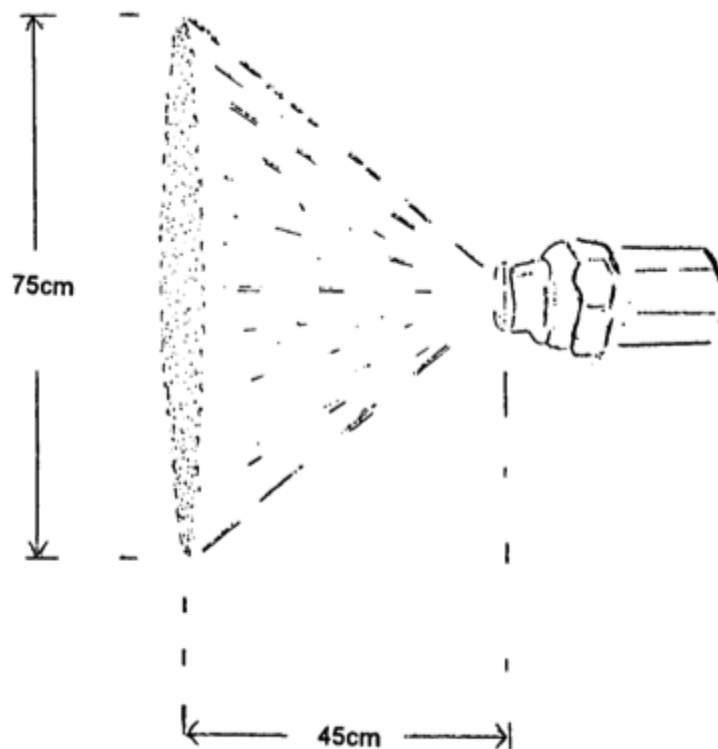

The fan-shaped spray at an angle of 80° gives a swath width of 75 cm with the nozzle tip at a distance of 45 cm from the wall.

- Emphasise that if the hand moves too fast, less insecticide is applied to the surface and vice versa. The aim of this lesson is for the spray man to learn the correct speed and movements necessary to achieve a correct and uniform spray.
- Demonstrate the rhythm of spraying on the already marked training surface.
- With the aid of a stopwatch or wristwatch with a second function let the trainee's count "One thousand and one, one thousand and two, one thousand and three, up to one thousand and ten"

in a time period of 10 seconds. It is important that spray men develop a "sense of time".

- Explain that in the spraying position facing the wall, a spray man will move his hand from the Upper position to the Lower position of a swath, counting loudly to achieve the right time/speed. (The correct time to complete a swath depends on the height of the available training surface (wall) and is calculated as follows: Height in M x 2,2 seconds.)
- In the same manner the spray man must move from the Lower to the Upper position.
- All trainees must practice while being timed by the instructor.

SPRAYING SUCCESSIVE SWATHS

- Spraying should begin at the top of the swath.
- Space the trainees in such a manner that each will be able to cover 2 swaths. They must be able to move to their right to

cover the second swath. After covering the first swath the spray man must take a step sideways to position himself in the middle of the next swath. Practice to get footwork right.

- Instructor must time the trainees and correct the speed where required.
- Trainees must practice until they are fluent in the change over between swaths and their timing is correct. Further swaths are now added until the spray man can cover all the swaths within 2 seconds of the allocated time.

Remember :

Tip of wooden extension should always almost touch the wall.

The sprayer must be well agitated before each exercise

Pressure gauge should be checked before the start of each exercise

Keep shut-off operating lever depressed although there is no pressure in the sprayer at this stage

PRESSURISATION OF SPRAYER

- Remove wooden extensions.

- Place a string or thin rope along the entire length of the wall, about 90cm from the ground and about 42/43cm away from the wall surface. In subsequent practice the string will serve as a guide to the correct distance of the nozzle tip from the wall. When the spray man reaches the middle position, the nozzle tip should be 2-3cm from the string.
- Explain how to pressurise the sprayer. Sprayer must be stabilised by keeping one foot on the "footrest". Unlock the plunger handle and pull the plunger rod all the way up. Use both hands to make full, even strokes from top to bottom. Short irregular strokes means more work and less pressure input per stroke.
- Describe the discharge line and its component parts and the "area of operation" (usually highlighted by a large green band between 25 and 55 psi.) on the pressure gauge. Pressure must always be kept within this range.
- Three trainees should fill their sprayers to the 10 litre mark and pressurise them to 55 psi. They should then assume the middle spraying position using the string as a guide for correct distance.
- The trainees now depress the shut-off operating levers and continue spraying until the pressure drops to 25 psi. when they release the operating levers.
- Check level of water remaining and note the average.
- One trainee should now fill the sprayer to the **8 litre** mark and apply pressure to 55 psi and then repeat the exercise.
- Check the level of water in the sprayer and compare with the first readings.

- The spray men will realise that:

The larger the size of the air cushion the less the need for repeated pumping to retain pressure.

As the liquid level goes down, more strokes are required to build up the required pressure but the pressure will last longer.

The spray man should not judge pressure but depend only on reading the pressure gauge.

SPRAYING WITH WATER

WHAT HAVE THE TRAINEES LEARNT SO FAR?

- **To fill the sprayer and apply pressure**
- **Maintaining the correct distance between the nozzle and the surface to be sprayed.**
- **The correct rhythm/velocity/speed of spraying**

- **The correct pacing from one swath to another**
- **The need to agitate the tank frequently**
- **The need to check and maintain the pressure**
- **Cleaning the sprayer**

The spray men must now **practice** all the above points spraying with water under supervision of the instructor **for as long as it takes to achieve perfection.**

FIRST TEST

- **Ensure that sprayers are filled to the 10 litre mark.**
- **Each trainee must make 5 consecutive sprayings of the practice surface, in the correct manner, in the allocated time. The time allocated for this exercise is calculated as follows:**

Height of swath in meters x 2,2 seconds x number of swaths.

The grade of efficiency is completion of spraying in the allocated time + or - 2 seconds.

Any variation greater than the above, is graded as "more practice required"

- **It is important not to concentrate on the speed of spraying only. Throughout the test, the instructor must check that the spray man adheres to all the principles that he has been**

taught e.g. distance, changing from one swath to another, agitating the contents of the sprayer, checking the pressure, etc. Any mistakes must be rectified immediately and the test repeated until the spray man is proficient. At the end of the test, the spray man must clean the sprayer in the way that he had been taught.

- The instructor must record the grade of efficiency of each trainee.

SPRAYING IN PRACTICE

Surface Areas That Should Be Sprayed.

- Traditional type structures.

Inside: Wall surface, behind door and the thatched roof.

Outside: Under the eaves and the top section of the wall.

- Western type structures.

Inside: Wall surfaces, behind door, ceilings and curtains.

- Outside latrines.

Inside: Wall surfaces under roof.

- Shelters e.g. tents, granaries, car wrecks, chicken house.

Surface Areas That Should Not Be Sprayed

- The overhang of roofs other than thatch e.g. corrugated iron, asbestos.
- Outside around doorways and windows.

Spraying Thatched Roofs

For the purpose of spraying, the roof is considered an extension of the wall. Therefore the first swath is begun on the roof, spraying continues downward to the floor. The second swath is then sprayed upwards from the floor to the maximum height that the spray man can reach, etc.

Spraying horizontal ceilings and roofs

Horizontal ceilings or roofs must be sprayed at the same speed, pressure and distance as is applicable for walls. The spray man should hold the lance in a vertical position at arms-length when spraying to minimize fall-out on the body.

Spraying in difficult/special situations

- *Pictures/calendars on walls.*

Spray over picture/calendar when fixed. Lift and spray the underside as well as the wall when possible.

- *Fixed furniture on or near the wall.*

Spray all sides even though it may not be possible to maintain the correct distance.

- *Immoveable furniture close to the wall.*

Introduce lance between the wall and the object and spray.

- *Objects leaning against the wall.*

Move the objects and spray the wall and, where possible, the objects as well before putting them back in position.

- *The undersides of objects close to the floor.*

It might be necessary to lie or kneel on the floor in order to spray.

Do not forget to spray under chairs and tables.

Remember the guiding principle "**WHEN IN DOUBT - SPRAY**".

PREPARATION, MIXING, SAFE HANDLING AND DISPOSAL OF INSECTICIDES AND WASH WATER.

Instructors must refer to the guidelines regarding the Safe Handling of Pesticides

FINAL TEST - Spraying under supervision

Trainees are now deployed in the field where they practice spraying typical structures that they will encounter in the normal work situation. This must be done under supervision and mistakes corrected by the instructor/supervisor.

Acknowledgements to J. J. P. LA GRANGE/WHO/Hudson Manufacturing Company

Prepared by: W. E. Farrell, Wefco Marketing International, Pietermaritzburg, RSA.

Original Version: 2008

First Revision: 2017

